

DH-PFA130-E-G

Water-proof Junction Box

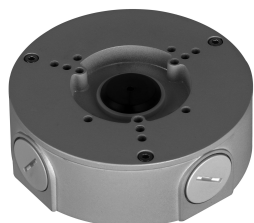

- Built of aluminum alloy.
- IP66 rated.
- Suitable for a variety of cameras and is elegant.



Series Overview

Dahua Junction Box is beautifully designed and highly convenient. Cables can be organized in it and there are outlets at the bottom and side of the box, making it easy to install and use.

Scene

Ideal for mounting cameras, it works in temperatures ranging from -40°C to $+60^{\circ}\text{C}$ (-40°F to $+140^{\circ}\text{F}$) and in environments with relative humidity of less than 90%.

Technical Specification

Structure

Casing Material	Aluminum alloy
Product Dimensions	$\Phi 124.3\text{ mm} \times 41.0\text{ mm}$ ($\Phi 4.89'' \times 1.61''$)
Appearance Color	Grey
Net Weight	0.34 kg (0.75 lb)
Gross Weight	0.40 kg (0.88 lb)
Load Bearing	3.0 kg (6.61 lb)
Installation	Junction mount
Screw Thread Type	G3/4
Applicable Model	Please see "Camera Accessories Selection"
Packaging Dimensions	$146\text{ mm} \times 65\text{ mm} \times 147\text{ mm}$ ($5.75'' \times 2.56'' \times 5.79''$) (L x W x H)

Environment

Protection	IP66
Operating Temperature	-40°C to $+60^{\circ}\text{C}$ (-40°F to $+140^{\circ}\text{F}$)
Operating Humidity	<90% (RH)
Storage Temperature	-40°C to $+60^{\circ}\text{C}$ (-40°F to $+140^{\circ}\text{F}$)
Storage Humidity	10%–90% (RH)
Anti-corrosion Level	Basic Protection

Ordering Information

Type	Model	Description
Camera Mount	DH-PFA130-E-G	Water-proof Junction Box

Installation

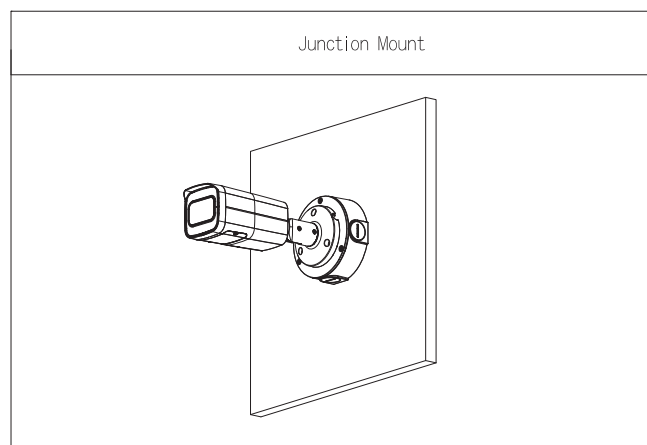

Dimensions (mm[inch])

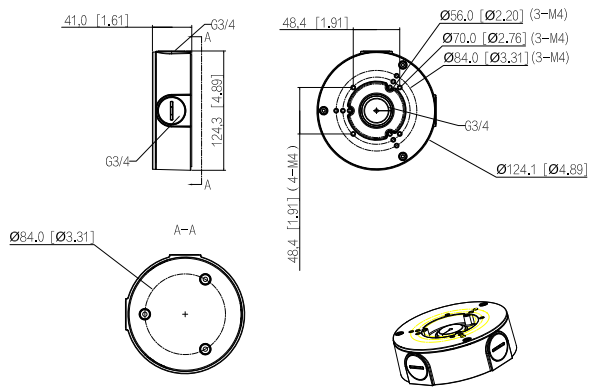

Package Information

- Water-proof junction box × 1
- M4×10 screw × 4
- ST4×25 screw × 3
- Plastic anchor × 3
- S3.0 wrench × 1
- Mounting sticker × 1